

# Communication Interface Module Replacement

## Removal Procedure

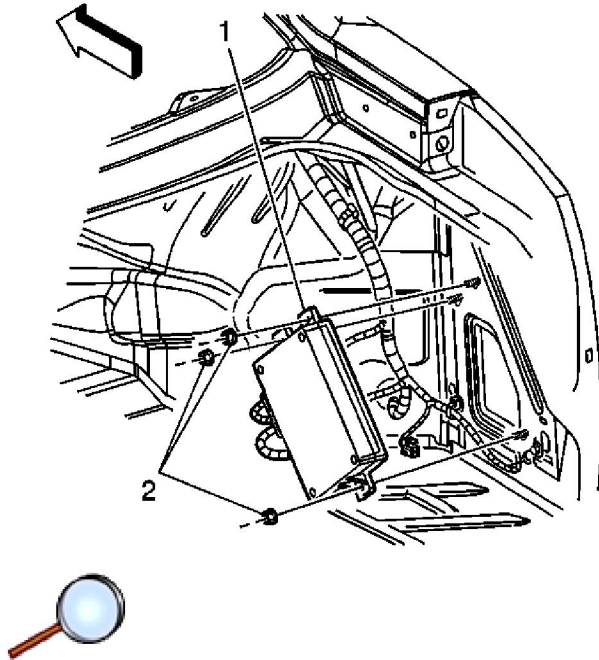

**Important:** The vehicle communication interface module (VCIM) has a specific set of unique numbers that tie the module to each vehicle. These numbers, the 10-digit station identification and the 11-digit electronic serial number, are used by the National Cellular Network and OnStar® to identify the specific vehicle. Because these numbers are tied to the vehicle identification number of the vehicle, you must never exchange these parts with those of another vehicle.

**Important:** This vehicle may be equipped with one of two versions of the OnStar® System.

Early production vehicles will have the generation 4 module and later productions will have the generation 5 module. The two modules cannot be interchanged. The generation 4 module can be identified by the use of three connector cavities. The generation 5 module uses four connector cavities.

1. Remove the right rear compartment trim. Refer to [Rear Compartment Trim Panel Replacement](#).
2. Remove the nuts (2) securing the OnStar® module (1) to the vehicle body.

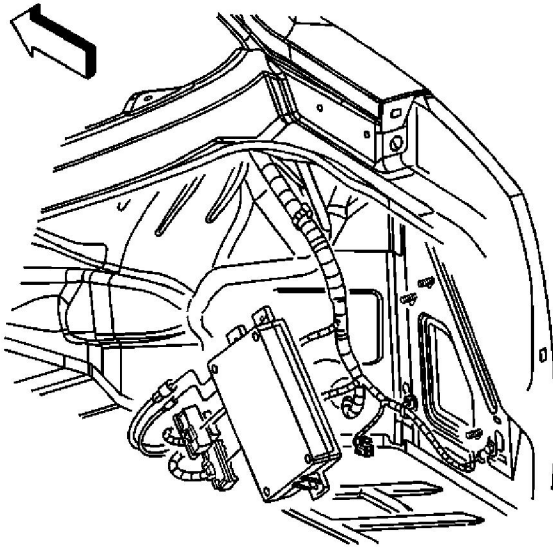

3. Disconnect all the electrical connectors from the module.
4. Remove the module from the vehicle.

### Installation procedure

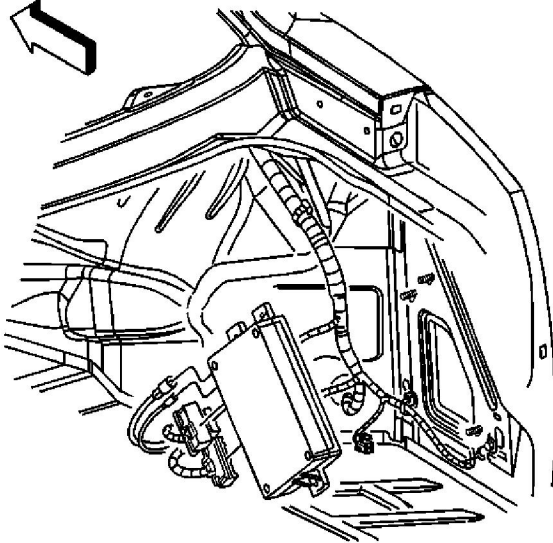

1. When replacing the VCIM, record the 11-digit electronic serial number (ESN) and the 10-digit station identification (STID) number from the label on the new VCIM.
2. Reconnect the electrical connectors the module.

**Notice:** Refer to [Fastener Notice](#) in the Preface section.

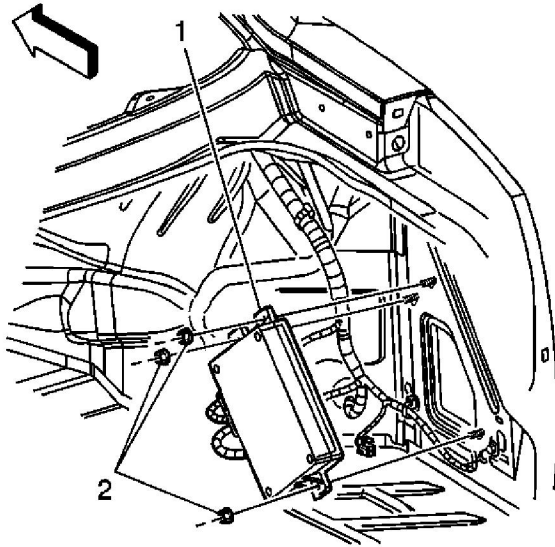

3. Install the module onto the vehicle.

**Tighten**

Tighten the nuts to 9 N·m (80 lb in).

**Important:** After replacing the vehicle communication interface module, you must reconfigure the OnStar® system. Failure to reconfigure the system will result in an additional customer visit for repair. In addition, pressing and holding the white dot button on the keypad will NOT reset this version of the OnStar® system. This action will cause a DTC to set.

4. Refer to [OnStar Reconfiguration](#) .